



**REQUEST FOR QUOTATION
FOR THE PROVISION OF**

**CONSTRUCTION SERVICES FOR
FIRE TRAINING GROUND REPLACEMENT – STEEL STRUCTURE ELECTRICAL
INSTALLATION**

BID CALL: OCTOBER 5, 2021

QUOTATIONS DUE: OCTOBER 19, 2021, AT 3:00 PM EST

2021-RFQ-108



REQUEST FOR QUOTATION
**CONSTRUCTION SERVICES FOR
 FIRE TRAINING GROUND REPLACEMENT – STEEL STRUCTURE
 ELECTRICAL INSTALLATION**
 2021-RFQ-108



Receipt Confirmation Schedule

To: City of Iqaluit – Purchasing Department
Attention: Alison Drummond
Title: Senior Director of Corporate Services
Address: 901 Nunavut Drive
 P.O Box 460
 Iqaluit, Nunavut, X0A 0H0
Fax: 867-979-5653
Email: a.drummond@iqaluit.ca

Bidders are requested to acknowledge receipt of 2021-RFQ-108 and their intent to submit a Quotation by sending this Receipt Confirmation Schedule by email to the attention of the RFQ Coordinator. Bidders submitting this Receipt Confirmation Schedule will be notified of any addendum issued to this RFQ, which will be forwarded to the person whose name is identified.

I hereby acknowledge receipt of this above-noted RFQ.

(Please check your answer)

I / We DO NO NOT Intend to submit a Quotation to this RFQ.

Representative's contact information:

Name

Address

City, Province/ Territory, Postal Code

Phone

Date

Representative's Signature

Name – Please Print

Title

Email

INITIALS _____



REQUEST FOR QUOTATION
**CONSTRUCTION SERVICES FOR
FIRE TRAINING GROUND REPLACEMENT – STEEL STRUCTURE
ELECTRICAL INSTALLATION**
2021-RFQ-108



PART 1 INTRODUCTION

1.1 Rules of Interpretation

This RFQ shall be interpreted according to the following provisions, unless the context requires a different meaning:

- a) Unless the context otherwise requires, wherever used herein the plural includes the singular, the singular includes the plural, and each of the masculine and feminine includes the other gender.
- b) Words in the RFQ shall bear their natural meaning unless otherwise expressly defined.
- c) In construing the RFQ, general words introduced or followed by the word *other* or *including* or *in particular* shall not be given a restrictive meaning because they are followed or preceded (as the case may be) by particular examples intended to fall within the meaning of the general words.
- d) Time periods will be strictly applied.
- e) The following terminology applies in the RFQ:
 - i. Whenever the terms *must* or *shall* are used in relation to the City of Iqaluit or the Bidder, such terms shall be construed and interpreted as synonymous and shall be construed to read *the City of Iqaluit shall* or the *Bidder shall*, as the case may be.
 - ii. The term “should” relates to a requirement which the City of Iqaluit would like the Bidder to address in its Quotation.
 - iii. The term *will* describes a procedure that is intended to be followed.

1.2 Role of the City of Iqaluit

This Request for Quotations is issued by the City of Iqaluit Purchasing Department (the “**City of Iqaluit**”) on behalf of the Engineering and Capital Projects Department.

The purchasing organization is the City of Iqaluit. The purchasing organization will administer the RFQ process described in the RFQ for the benefit of the Purchasers.

Once a contract has been established with the successful Bidder, the project will be overseen by the City’s Project Manager. The Project Manager assigned to this project is Josh Benoit.

1.3 City of Iqaluit Background

INITIALS _____



REQUEST FOR QUOTATION
**CONSTRUCTION SERVICES FOR
FIRE TRAINING GROUND REPLACEMENT – STEEL STRUCTURE
ELECTRICAL INSTALLATION**
2021-RFQ-108



Iqaluit is the capital of the Nunavut Territory and is located at the south end of Baffin Island near the end of Frobisher Bay. Access to Iqaluit is provided by regular scheduled commercial aircraft year-round, snowmobile trails from other Baffin Island communities in the winter, and sealift from the port of Montreal and Valleyfield in the summer.

The City is the newest Capital City in Canada and as a result has experienced a period of rapid development and growth. Iqaluit is the seat of government for the Territory of Nunavut and is the home base of many federal and territorial government departments. The City is rapidly developing into a regional center for the territory with many northern businesses in Inuit organizations making it their base of operations. The current population of Iqaluit is estimated at about 7,000 people with an average annual growth rate between three and four percent.

1.4 Products and Services

This RFQ is issued for the purpose of obtaining Quotations for the supply, installation, and commissioning of all materials and systems identified in the attached drawing set for the City of Iqaluit. The RFQ provides contractors with relevant information pertaining to the services required.

1.5 Objectives

The City of Iqaluit is seeking to satisfy the following objectives in issuing this RFQ:

- a) Have the contractor supply install of the specified electrical equipment and materials in the steel structure at the City's Fire Training Grounds (adjacent to the West 40 Landfill)
- b) Have the contractor commission the electrical installations

INITIALS _____



REQUEST FOR QUOTATION
**CONSTRUCTION SERVICES FOR
 FIRE TRAINING GROUND REPLACEMENT – STEEL STRUCTURE
 ELECTRICAL INSTALLATION**
 2021-RFQ-108



PART 2 RFQ TERMS AND INSTRUCTIONS

2.1 Submission

Bidders must submit electronic (PDF) copies of their Bid(s). Emails are to be received before 3:00 PM EST on October 19, 2021, addressed to:

Alison Drummond
 Senior Director of Corporate Services
 City of Iqaluit
a.drummond@iqaluit.ca

Emails should be clearly marked in the subject line the “Fire Training Ground Replacement – Steel Structure Electrical Installation” and the Bidders name. Bidders shall submit a Cost Submission form identifying the corresponding costs.

The total size of email submissions should be less than 5MB in size to facilitate delivery and adequate time must be allowed for delivery. It is the Bidder’s responsibility to confirm successful receipt of the email submission prior to the deadline.

The final decision on whether to accept late Quotations is at the City’s discretion.

2.2 Inquiries and Amendments

All inquiries concerning this RFQ (up until any contract award notification) are to be directed by email only to:

Alison Drummond
 Senior Director of Corporate Services
 City of Iqaluit
a.drummond@iqaluit.ca

The deadline for submitting inquiries is 3:00 PM EST on October 12, 2021.

To ensure consistency and fairness to all Bidders, all firms who have received the RFQ will receive any information with respect to significant inquiries in the form of written addenda. Verbal explanations or instructions will not be provided.

2.3 Bidder Requirements

The successful Bidder must have a valid City of Iqaluit Business License prior to contract award.

2.4 Solicitation of Council Members, City Staff and City Consultants

INITIALS _____



REQUEST FOR QUOTATION
**CONSTRUCTION SERVICES FOR
FIRE TRAINING GROUND REPLACEMENT – STEEL STRUCTURE
ELECTRICAL INSTALLATION**
2021-RFQ-108



Bidders and their agents will not contact any member of the City Council, City Staff or City Consultants with respect to this RFQ, other than the RFQ Coordinator named in Section 2.2, at any time prior to the award of a contract or the cancellation of this RFQ.

2.5 Terms and Conditions

- 2.5.1 Submission of a Bid constitutes acknowledgement that the Bidder has read and agrees to be bound by all the terms and conditions of this RFQ.
- 2.5.2 The City will not make any payments for the preparation of a response to this RFQ. All costs incurred by a Bidder will be borne by the Bidder.
- 2.5.3 This is not an offer. The City does not, by virtue of this Bid call, commit to an award of a Bid, nor does it limit itself to accepting the lowest price or any Bid submitted, but reserves the right to award this Bid in any manner deemed to be in the City's best interest.
- 2.5.4 The City has the right to cancel this RFQ at any time and to reissue it for any reason whatsoever, without incurring any liability and no Bidder will have any claim against the City as a result of the cancellation or reissuing of the RFQ.
- 2.5.5 A Bidder may withdraw its Quotation only by providing written notice to the RFQ Coordinator before the RFQ Submission Deadline. A Quotation may not be withdrawn after the RFQ Submission Deadline. The City of Iqaluit has no obligation to return withdrawn Quotations.
- 2.5.6 A Bidder may amend its Quotation after submission, but only if the Quotation is amended and resubmitted before the RFQ Submission Deadline. The Bidder must provide notice to the RFQ Coordinator in writing and replace its Quotation with a revised Quotation, in accordance with the requirements of this RFQ. The City of Iqaluit has no obligation to return amended Quotations.
- 2.5.7 The City will not be responsible for any Bid that does not indicate the RFQ reference, and the Bidder's name.
- 2.5.8 The City will not be responsible for any Bid that is delivered to any address or in any manner other than that provided in Section 2.1 of this RFQ.
- 2.5.9 If a contract(s) is to be awarded as a result of this RFQ, it will be awarded to the Bidder whose Bid for each service, in the City's opinion, provides the best potential value to the City and is capable in all respects to perform fully the contract requirements and has the integrity and reliability to assure performance of the contract obligations.
- 2.5.10 If the City decides to award a contract(s) based on a submission received in response to this RFQ, the Successful Bidder(s) will be notified of the intent to award in writing, and the subsequent execution of a written agreement shall constitute the making of a

INITIALS _____



REQUEST FOR QUOTATION
**CONSTRUCTION SERVICES FOR
FIRE TRAINING GROUND REPLACEMENT – STEEL STRUCTURE
ELECTRICAL INSTALLATION**
2021-RFQ-108



Contract. Bidders will not acquire any legal or equitable rights or privileges whatsoever until a Contract is signed by both parties.

- 2.5.11 In the event of any inconsistency between this RFQ, and any ensuing Contract(s), the Contract shall govern.
- 2.5.12 Any Contract(s) will be in the form of the City's standard "City of Iqaluit Services Agreement" and it will contain the relevant provisions of this RFQ, the accepted Bid as well as such other terms as may be mutually agreed upon, whether arising from the accepted Bid or as a result of any negotiations prior or subsequent thereto. The City reserves the right to negotiate modifications with any Bidder who has submitted a Bid.
- A copy of the Services Agreement is included as Appendix A.
- 2.5.13 Any amendment made by the City to the RFQ will be issued in writing and sent to all who have received the documents via addenda.
- 2.5.14 An Evaluation Committee will review each Bid. The City reserves the exclusive right to determine the qualitative aspects of all Quotations relative to the evaluation criteria.
- 2.5.15 Quotations will be evaluated as soon as practicable after the closing time. No detail of any Bid will be made public except the names of all parties submitting Quotations.
- 2.5.16 Bidders must acknowledge receipt of any addenda issued by the City in their Bid.
- 2.5.17 Every Bidder shall carefully review the RFQ to ensure that it has no reason to believe there are any uncertainties, inconsistencies, errors, omissions, or ambiguities in any part of the RFQ. Every Bidder is responsible for conducting its own investigations and due diligence necessary for the preparation of its Quotation.
- 2.5.18 In the event a Bidder has any reason to believe that any of the circumstances listed in Section 2.5.17 exist, the Bidder shall notify the RFQ Coordinator in writing prior to submitting a Quotation. The RFQ Coordinator will then clarify the matter for the benefit of all Bidders.
- 2.5.19 Bidders shall not:
- a) After submission of a Quotation, claim that there was any misunderstanding or that any of the circumstances set out in 2.5.17 were present with respect to the RFQ; or
 - b) Claim that the City of Iqaluit is responsible for any of the circumstances listed in Section 2.5.17.
- 2.5.20 By submitting a Quotation, the Bidder confirms that all of the components required to use and/or manage the Services have been identified in its Quotation or will be provided to the City of Iqaluit at no additional charge. Any requirement that may be

INITIALS _____



REQUEST FOR QUOTATION
**CONSTRUCTION SERVICES FOR
FIRE TRAINING GROUND REPLACEMENT – STEEL STRUCTURE
ELECTRICAL INSTALLATION**
2021-RFQ-108



identified by the Bidder after the RFQ Submission Deadline or subsequent to signing the Agreement shall be provided at the Bidder's expense.

2.6 Clarification of Bidder's Quotation

The City of Iqaluit shall have the right at any time after the RFQ Submission Deadline to seek clarification from any Bidder in respect of that Bidder's Quotation. The City of Iqaluit shall not be obliged to seek clarification of any aspect of any Quotation.

Any clarification sought shall not be an opportunity for the Bidder to either correct errors or to change the Bidder's Quotation in any substantive manner. Subject to the qualification in this provision, any written information received by the City of Iqaluit from a Bidder in response to a request for clarification from the City of Iqaluit may be considered to form an integral part of the Bidder's Quotation, in the City of Iqaluit's sole discretion.

2.7 Verification of Information

The City of Iqaluit shall have the right, in its sole discretion, to:

- a) Verify any Bidder's statement or claim made in the Bidder's Quotation or made subsequently in an interview, site visit, oral presentation, demonstration, or discussion by whatever means the City of Iqaluit may deem appropriate, including contacting persons in addition to those offered as references;
- b) reject any Bidder's statement, claim or Quotation, if such statement, claim or Quotation is patently unwarranted or is questionable; or
- c) access the Bidder's premises where any part of the work is to be carried out to confirm Quotation information, quality of processes, and to obtain assurances of viability, provided that, prior to providing such access, the Bidder and City of Iqaluit shall agree on reasonable access terms, including pre-notification, extent of access, security, confidentiality and the allocation and amount of any costs incurred in connection with such access.

The Bidder shall co-operate in the verification of information and is deemed to consent to the City of Iqaluit verifying such information.

2.7 Validity of Offer

Quotations shall remain open for acceptance for a period of not less than sixty calendar (60) days from the closing date of this RFQ.

INITIALS _____



REQUEST FOR QUOTATION
**CONSTRUCTION SERVICES FOR
FIRE TRAINING GROUND REPLACEMENT – STEEL STRUCTURE
ELECTRICAL INSTALLATION**
2021-RFQ-108



PART 3 BID REQUIREMENTS AND EVALUATION

3.1 Quotation Format

3.1.1 General

The Bidder's Quotation should be comprised and formatted as follows:

- a) One (1) electronic copy, of a fully executed unqualified Cost Submission Form (PDF format), titled "Cost Submission Form – Fire Training Ground Replacement – Steel Structure Electrical Installation".

3.1.2 Legal Actions

The Bidder shall disclose any pending or threatened legal action against the Bidder or by the Bidder against any third party that may have an impact on the availability of the Services proposed by the Bidder.

3.1.3 Declaration and Certification

The Bidder shall complete the Declaration and Certification Schedule in accordance with the instructions contained in that schedule.

3.1.4 Cost Submission Form

The Bidder shall complete the Cost Submission Form in accordance with the instructions contained in that schedule, provided that the following shall apply:

- a) All prices shall be provided in Canadian funds and shall include all applicable customs duties, tariffs, overhead, permits, licenses, labour, carriage insurances, and warranties, and further shall not be subject to adjustment for fluctuation in foreign exchange rates. All prices shall be quoted exclusive of the goods and services taxes (GST);
- b) The Quotation submitted for the services requested will be based on a fixed fee amount.
- c) All prices quoted, unless otherwise instructed in this RFQ, shall remain firm for the period set out in the RFQ;
- d) All prices quoted **MUST** be for units that originate from the Canadian marketplace. No "Grey Market" product pricing will be accepted.
- e) Travel and accommodation expenses shall not be included in the rates quoted and shall be billed separately and charged in accordance with the applicable

INITIALS _____



REQUEST FOR QUOTATION
**CONSTRUCTION SERVICES FOR
 FIRE TRAINING GROUND REPLACEMENT – STEEL STRUCTURE
 ELECTRICAL INSTALLATION**
 2021-RFQ-108



Purchaser’s policy, as may be amended from time to time. Original itemized receipts are required for reimbursement. Meals, hospitality, and other incidentals shall not be included in eligible expenses;

- f) In the event of any discrepancy in the pricing, the lowest unit price submitted shall prevail; and
- g) The Bidder is deemed to confirm that it has prepared its Quotation with reference to all of the provisions, and that it has factored all of the provisions of the Agreement into its pricing assumptions, calculations and into its proposed Pricing.

3.2 Evaluation Process

The City will appoint an Evaluation Committee for the purpose of evaluating Quotations. Quotation evaluations will follow a two-step process:

- a) Validation of mandatory requirements;
- b) Financial evaluation;

Quotations that do not meet the mandatory requirements will not be considered further.

3.3 Mandatory Requirements

Bidders must satisfy the following mandatory requirements in their Quotation in accordance with the requirements of this RFQ. Bidders shall submit the following:

- a) Fully executed and unconditional Cost Submission Form.
- b) Initials of acknowledgement on all RFQ pages (located on the bottom of each page).

3.4 Financial Evaluation

The Bidder who submits a Quotation with the lowest compliant financial offer will be successful as part of the financial evaluation.

3.5 RFQ Schedule

The following is a summary of the key dates in the RFQ process and the Works:

Table 1 – RFP Process Schedule

Milestone	Date
-----------	------

INITIALS _____



REQUEST FOR QUOTATION
**CONSTRUCTION SERVICES FOR
 FIRE TRAINING GROUND REPLACEMENT – STEEL STRUCTURE
 ELECTRICAL INSTALLATION**
 2021-RFQ-108



RFQ Issue Date	October 5, 2021
Last Day for Bidder to Submit Questions	October 12, 2021
Last Date for Addenda to be Issued	October 14, 2021
RFP Submission Deadline	October 19, 2021
Notification Date	October 26, 2021
Anticipated Contract Award Date	October 26, 2021
Anticipated Project Start/ Kick-Off Meeting	October 26, 2021
Substantial Completion	December 31, 2021

3.6 Terms of Payment

The Bidder shall be reimbursed monthly for works completed for each service provided. Invoices are to be submitted on a monthly basis, and shall include:

- the project title.
- the service contract number.
- a description of the work completed.
- billing summary, which includes the tasks as set forth in the costing submission, the proposed costs, cost to date, percentage invoiced to date, and the percentage of work completed to date for each task.
- backup for all disbursements (time sheets may be requested).

The monthly invoice should be reviewed as a draft by the City’s Project Manager in order to validate the fee and services being claimed. The Bidder is to update the invoice (as required), as per comments/ feedback received from the City’s Project Manager. The City’s Project Manager and Bidder are to determine at the Project Kick-Off meeting the date which draft monthly invoices are to be reviewed.

The final invoice is to be submitted to the City’s Project Manager for processing with the City. Invoices that are issued directly to the City’s Accounts Payable Department will not be processed. Final invoices must be submitted for payment by the 10th of every month, for previous months work (e.g. invoice must be submitted by February 10th for work completed up to January 31st), or on the next corresponding business day if the 10th lies on a holiday or weekend.

No payment will be made for the cost of work incurred to remedy errors or omissions for which the contractor is responsible. No additional invoicing will be accepted above

INITIALS _____



REQUEST FOR QUOTATION
**CONSTRUCTION SERVICES FOR
FIRE TRAINING GROUND REPLACEMENT – STEEL STRUCTURE
ELECTRICAL INSTALLATION**
2021-RFQ-108



and beyond what the City has agreed to as per the contract. At no time shall the contract upset limit be exceeded without prior written authorization from the City.

PART 4 SCOPE OF WORK

4.1 Scope of Work

The Bidder will be responsible for all materials labour, and equipment required to execute the scope of work. The following describes the Scope of Work for the project:

1. Supply, installation, and commissioning of the attached drawings 01-E-1001, 01-E-1002, 01-E-1003, and 01-E-1004.

INITIALS _____



REQUEST FOR QUOTATION
**CONSTRUCTION SERVICES FOR
 FIRE TRAINING GROUND REPLACEMENT – STEEL STRUCTURE
 ELECTRICAL INSTALLATION**
 2021-RFQ-108



COST SUBMISSION FORM

The Bidder should use the following charts to respond to the Part 4 Scope of Work requirements.

Bidder Name _____

No.	Item/ Description	Qty	Unit	Unit Price	Total
1.	Mobilization/demobilization	1	LS	\$	\$
2.	Supply and installation of all specified materials, including appropriate permits.	1	LS	\$	\$
3.	Coordination with structural and mechanical contractors (may be onsite at the same time)	1	LS		
4.	Commissioning (incl. all coordination with local authorities, contractors, etc.)	1	LS	\$	\$
SUBTOTAL (excl. GST):					\$
Applicable Taxes (GST):					\$
TOTAL (Incl. GST):					\$

INITIALS _____



REQUEST FOR QUOTATION
**CONSTRUCTION SERVICES FOR
 FIRE TRAINING GROUND REPLACEMENT – STEEL STRUCTURE
 ELECTRICAL INSTALLATION**
 2021-RFQ-108



UNFAIR ADVANTAGE AND CONFLICT OF INTEREST STATEMENT SCHEDULE

In the event that the boxes below are left blank, the Bidder shall be deemed to declare that (a) it has had no Unfair Advantage in preparing its Quotation and (b) there is no foreseeable actual or potential Conflict of Interest in performing the contractual obligations contemplated in the RFQ.

If either or both of the statements below apply, check the appropriate box:

- The Bidder declares that there is an actual or potential Unfair Advantage relating to the preparation of
- The Bidder declares that there is an actual or potential Conflict of Interest in performing the contractual obligations contemplated in the RFQ.

In the event the Bidder declares an actual or potential Unfair Advantage and/or an actual or potential Conflict of Interest (by marking either of the boxes above), the Bidder shall provide all relevant detailed information below.

The Bidder agrees to provide any additional information which may be requested by the RFQ Coordinator, in the form prescribed by the RFQ Coordinator.

Where, in its sole discretion, the City of Iqaluit concludes that an Unfair Advantage and/or Conflict of Interest arises, it may, in addition to any other remedy available to it at law or in equity, disqualify the Bidder’s Quotation, or terminate any Agreement awarded to the Bidder under the RFQ.

INITIALS _____



REQUEST FOR QUOTATION
**CONSTRUCTION SERVICES FOR
 FIRE TRAINING GROUND REPLACEMENT – STEEL STRUCTURE
 ELECTRICAL INSTALLATION**
 2021-RFQ-108



DECLARATION AND CERTIFICATION SCHEDULE

TO: City of Iqaluit

RE: In the matter of our Quotation dated [insert] to which this Declaration and Certification Schedule is an integral part the Quotation prepared by [insert] and submitted in response to a Request for Quotations issued by the City of Brockville dated [Insert] as amended, regarding the selection of a Bidder to execute the Agreement pursuant to the RFQ.

I am duly authorized by the Bidder, including the persons, firms, corporations, and advisors joining in the submission of this Quotation, to execute this Declaration and Certification Schedule. I solemnly declare and certify as follows:

1. Bidder Information

a) The full legal name of the Bidder is:

b) Any other registered business name under which the Bidder carries on business is:

c) The jurisdiction under which the Bidder is formed is:

d) The name, address, telephone number, and email address of the contact person for the Bidder:

2. Offer

The Bidder has carefully examined the RFQ documents and has a clear and comprehensive knowledge of what is required under the RFQ. By submitting its Quotation, the Bidder agrees and consents to the terms, conditions, and provisions of the RFQ, except as otherwise noted, and offers to provide the Services in accordance therewith at the Rates set out in the Cost Submission Form.

3. Pricing

INITIALS _____



REQUEST FOR QUOTATION
**CONSTRUCTION SERVICES FOR
 FIRE TRAINING GROUND REPLACEMENT – STEEL STRUCTURE
 ELECTRICAL INSTALLATION**
 2021-RFQ-108



The Bidder has submitted its Pricing in accordance with the instructions in the RFQ and in the form set out in the Cost Submission Form.

4. Quotation Irrevocable

The Bidder agrees that its Quotation shall be irrevocable for 60 calendar days following the Quotation RFQ Submission Deadline.

5. Disclosure of Information

The Bidder hereby agrees that any information provided in this Quotation, even if it is identified as being supplied in confidence, may be disclosed where required by law or if required by order of a court or tribunal. The Bidder hereby consents to the disclosure, on a confidential basis, of its Quotation to the City of Iqaluit’s advisors retained for the purpose of evaluating or participating in the evaluation of this Quotation.

6. Proof of Insurance and Good Standing Under the Workers’ Safety Compensation Commission

By signing this Declaration and Certification Schedule, the Bidder agrees, if selected, that it has verified its capability to do so and will provide proof of insurance coverage and a Certificate of Good Standing under the Workers’ Safety Compensation Commission (Nunavut).

7. Execution of Agreement

If its Quotation is selected by the City of Iqaluit, the Bidder agrees to finalize and execute the Agreement in accordance with the terms of the RFQ.

Signature of Witness

Signature of Bidder Representative,
who has authority to bind the Bidder

Name of Witness

Name and Title of Representative, who
has authority to bind the Bidder

Date

INITIALS _____



REQUEST FOR QUOTATION
**CONSTRUCTION SERVICES FOR
 FIRE TRAINING GROUND REPLACEMENT – STEEL STRUCTURE
 ELECTRICAL INSTALLATION**
 2021-RFQ-108



APPENDIX A – CITY OF IQALUIT SERVICE AGREEMENT

BETWEEN: THE MUNICIPAL CORPORATION OF THE CITY OF IQALUIT
 (hereinafter referred to as the "CITY OF IQALUIT")

OF THE FIRST PART

AND: . **<CONTRACTOR NAME>**
 (hereinafter referred to as the "Contractor")

OF THE SECOND PART

WHEREAS the CITY OF IQALUIT has requested the Contractor to provide **<description of services>**;

AND WHEREAS the Contractor has agreed to provide such services to the CITY OF IQALUIT in its bid dated **<Bid Submission Date>**;

AND WHEREAS the CITY OF IQALUIT and the Contractor wish to set out the terms and conditions relating to the provision of such services;

THEREFORE, the CITY OF IQALUIT and the Contractor agree as follows:

1. SERVICES AND PAYMENT

1.1 The Contractor agrees to provide to the CITY OF IQALUIT those services set out in the job description and scope of work provided on **<RFT Date>**. A copy of the bid is attached as Appendix "A".

1.2 The CITY OF IQALUIT agrees to pay for the services described above, a total amount not greater than **<Bid Value>**, for the provision of professional services based on the Bid dated **<Bid Submission Date>**.

2. TERM

2.1. This Contract shall commence on the **<Contract Commence Date>** and terminates on the **<Contract Termination Date>** unless otherwise terminated in accordance with the provisions of this Contract.

3. NOTICE AND ADDRESS

3.1 Any notice required to be given herein or any other communication required by this contract shall be in writing and shall be personally delivered, sent by facsimile, or posted by prepaid registered mail and shall be addressed as follows:

INITIALS _____



REQUEST FOR QUOTATION
**CONSTRUCTION SERVICES FOR
 FIRE TRAINING GROUND REPLACEMENT – STEEL STRUCTURE
 ELECTRICAL INSTALLATION**
 2021-RFQ-108



i) If, to the CITY OF IQALUIT:

Amy Elgersma
 Chief Administrative Officer
 City of Iqaluit
 P.O. Box 460
 Iqaluit, NU
 X0A 0H0
 Fax: 979-5922

Reference:

ii) If to the Contractor at:

<Contractor Representative – Name>
 <Contractor Organization Name>
 <Contractor Address>

3.2 Every such notice and communication, if delivered by hand, shall be deemed to have been received on the date of delivery or if sent by prepaid registered mail shall be deemed to have been received on the seventh day after posting, or if by facsimile, 48 hours after the time of transmission, excluding from the calculation weekends and statutory holidays.

4. COMPLETE AGREEMENT

4.1 This Contract and its attachments constitute the complete Contract between the parties. Except as provided herein, it supersedes and shall take effect in substitution for all previous agreements. It is subject to change only by an instrument executed in writing by the City.

4.2 If this Contract arises from a request for proposals or tender call, the provisions of the request for proposals or tender call and the Contractor's bid or proposal submission are incorporated into this Contract and may be used to clarify, explain or supplement this Contract, but shall not be used to contradict any express terms of this Contract.

4.3 In the event of a conflict between this Contract, the Contractor's bid or proposal submission, and the City's original tender bid instructions or Request for Proposals, the more recently prepared document shall govern to the extent of such inconsistency.

5. GENERAL TERMS

5.1 Any information obtained from or concerning any department of the CITY OF IQALUIT or clients of any department of the CITY OF IQALUIT, by the contractor, its agents or employees in the performance of any contract shall be confidential. The Contractor shall take such steps as are necessary to ensure that any such information is not disclosed to any other person and shall maintain confidential and secure all material and information that is the property of the CITY OF IQALUIT and in the possession of or under the control of the Contractor. This clause survives the termination of this contract.

5.2 Time shall in every respect be of the essence. The Contractor shall deliver the services specified in the contract and according to the project schedule on costs. The CITY OF IQALUIT may grant reasonable extensions to the Contractor for delays, if the Contractor can show those delays were caused by circumstances beyond the control of the Contractor.

5.3 The Contractor is an independent Contractor with the CITY OF IQALUIT and nothing in this contract shall be construed or deemed to create the relationship of employee and employer or of principal and agent between the CITY OF IQALUIT and the Contractor. The Contractor is solely responsible for

INITIALS _____



REQUEST FOR QUOTATION
**CONSTRUCTION SERVICES FOR
FIRE TRAINING GROUND REPLACEMENT – STEEL STRUCTURE
ELECTRICAL INSTALLATION**
2021-RFQ-108



payments of all statutory deductions or contributions including but not limited to pension plans, unemployment insurance, income tax, workers' compensation and the Nunavut Payroll Tax.

- 5.4 This contract shall be interpreted and governed in accordance with the laws of Nunavut and the laws of Canada as they apply in Nunavut.
- 5.5 No waiver by either party of any breach of any term, condition or covenant of this contract shall be effective unless the waiver is in writing and signed by both parties. A waiver, with respect to a specific breach, shall not affect any rights of the parties relating to other or future breaches.
- 5.6 The failure of either party at any time to require the performance of any provision or requirement of this contract shall not affect the right of that party to require the subsequent performance of that provision or requirement.
- 5.7 Title to any report, drawing, photograph, plan, specification, model, prototype, pattern, sample, design, logo, technical information, invention, method or process and all other property, work or materials which are produced by the Contractor in performing the contract or conceived, developed or first actually reduced to practice in performing the contract (herein called "the Property") shall vest in the CITY OF IQALUIT and the Contractor hereby absolutely assigns to the CITY OF IQALUIT the copyright in the property for the whole of the term of the copyright. The Contractor shall not be responsible for any loss or damage suffered by the City of Iqaluit or any third parties resulting from any unauthorized use or modification of the property, errors in transmission of the property, changes to the Property by others, the consequences of design defects due to the design of others, or defects in contract documents prepared by others, and the City of Iqaluit agrees to defend, indemnify, and hold the Contractor harmless from and against all claims, demands, losses, damages, liability and costs associated therewith. Subject to the foregoing, the Property may be relied by the City of Iqaluit for design and construction work undertaken by other parties with respect to the Services provided that such parties verify the accuracy and completeness of the Property to their satisfaction.
- 5.8 It is intended that all provisions of this agreement shall be fully binding and effective between the parties, but in the event that any particular provision or provisions or a part of one is found to be void, voidable or unenforceable for any reason whatever, then the remainder of the agreement shall be interpreted as if such provision, provisions, or part thereof, had not been included.
- 5.9 This contract may be extended by the written consent of the parties.
- 5.10 The CITY OF IQALUIT may delegate any of its authority and undertaking pursuant to this contract to any employee or contractor the CITY OF IQALUIT by notice in writing to the Contractor.
- 5.11 This contract shall enure to the benefit of and be binding on the respective administrators, successors and assignment of each of the parties hereto.
6. CONTRACTOR RESPONSIBILITIES
- 6.1 The Contractor shall indemnify and hold harmless, the CITY OF IQALUIT, its officers, employees, servants and agents from and against all claims, actions, causes of action, demands, losses, costs, damages, expenses, suits or other proceedings by whomsoever made, brought or prosecuted in any manner based upon or related to the negligent acts, errors, or omissions of the Contractor under this contract.
- 6.2 The Contractor shall be liable to the CITY OF IQALUIT for any loss or damage to property or equipment that is supplied to or placed in the care, custody or control of the Contractor for use in connection with the contract if such loss or damage is attributable to the negligence or deliberate acts of the Contractor or its employees or agents.

INITIALS _____



REQUEST FOR QUOTATION
**CONSTRUCTION SERVICES FOR
FIRE TRAINING GROUND REPLACEMENT – STEEL STRUCTURE
ELECTRICAL INSTALLATION**
2021-RFQ-108



- 6.3 If, in the opinion of the CITY OF IQALUIT acting reasonably, the Contractor is in default in respect of any obligation of the Contractor hereunder, the CITY OF IQALUIT may rectify such default and pursue a claim against the Contractor for any direct costs associated with any such remediation, including a reasonable allowance for the use of the CITY OF IQALUIT's own employees or equipment.
- 6.4 The Contractor may not assign or delegate work to be done under this contract, or any part thereof, to any other party without the written consent of the CITY OF IQALUIT. In the case of a proposed assignment of monies owing to the Contractor under this contract, the consent in writing of the CITY OF IQALUIT must be obtained.
- 6.5 The Contractor shall keep proper accounts and records of the services for a period of 3 years after the expiry or termination of this agreement. At any time during the term of this contract or during the three years following the completion or termination of this agreement, the Contractor shall produce copies of such accounts and records upon the written request of the CITY OF IQALUIT.
- 6.6 The Contractor shall notify the CITY OF IQALUIT immediately of any claim, action, or other proceeding made, brought, prosecuted or threatened in writing to be brought or prosecuted that is based upon, occasioned by or in any way attributable to the performance or non-performance of the services under this contract.
- 6.7 If at any time the Contractor considers their estimates indicate costs will exceed the project budget they will immediately advise the City of Iqaluit. If in the opinion of the City of Iqaluit, acting reasonably, the excess is due to design, costs factors or matters under the control or reasonably foreseeable by the Contractor, the CITY OF IQALUIT may require the Contractor to do everything by way of revision of the design to bring the cost estimate within the project budget. Costs of completing such revisions shall be based upon a level of compensation reasonably appropriate to the circumstances, including the reason for the revisions.
- 6.8 Except as required in the performance of services set out in this agreement, the Contractor must maintain as confidential all data and information made available to the Contractor, the CITY OF IQALUIT, or any other parties which is generated by or results from the Contractor's performance of the Services described in this Contract. All such data and information is the property of the City of Iqaluit. This clause shall survive the termination of the Contract.

7. TERMINATION

- 7.1 The CITY OF IQALUIT may terminate this contract at any time upon giving written notice to this effect to the Contractor if, in the opinion of the CITY OF IQALUIT, the Contractor is unable to deliver the service as required, the Contractor's performance of work is persistently faulty, in the event that the Contractor becomes insolvent or commits an act of bankruptcy, in the event that any actual or potential labor dispute delays or threatens to delay timely performance of the contract or the (Contractor's Sub-Contractor) defaults or fails to observe the terms and conditions of the contract in any material respect.
- 7.2 This contract shall terminate as of the day for termination set out in the written notice and the Contractor shall forthwith invoice the CITY OF IQALUIT for work performed to the date of termination.
- 7.3 Any invoice submitted by the Contractor pursuant to clause 7.2 shall be reviewed by the CITY OF IQALUIT to assess the amount which is properly due and owing for work done by the Contractor prior to termination.

8. FINANCIAL

INITIALS _____



REQUEST FOR QUOTATION
**CONSTRUCTION SERVICES FOR
FIRE TRAINING GROUND REPLACEMENT – STEEL STRUCTURE
ELECTRICAL INSTALLATION**
2021-RFQ-108



- a. The CITY OF IQALUIT, having given written notice of a breach, may withhold or hold back in whole or in part any payment due the Contractor without penalty, expense or liability, if in the opinion of the Contracting Authority, the Contractor has failed to comply with or has in any way breached an obligation of the Contractor. Any such hold back shall continue until the breach has been rectified to the satisfaction of the CITY OF IQALUIT.
 - 8.2 The CITY OF IQALUIT may set off any payment due the Contractor against any monies owed by the Contractor to the CITY OF IQALUIT.
 - 8.3 The City of Iqaluit will pay the Goods and Services Tax (GST).
 - 8.4 Provided all terms and conditions on the part of the Contractor have been complied with, each invoice will be paid thirty (30) calendar days after receipt of the invoice, or thirty (30) calendar days after delivery of the services, whichever is later. Invoices from Nunavut Contractors (as defined by the CITY OF IQALUIT NNI Policy) will be paid twenty (20) calendar days after receipt of the invoice, or twenty (20) calendar days after receipt of the services, whichever is later.
 - 8.5 The CITY OF IQALUIT may, in order to discharge lawful obligations or to satisfy lawful claims against the Contractor or a Sub-Contractor arising out of the execution of work, pay any amount, which is due and payable to the Contractor under the contract, if any, directly to the obligee of and the claimants against the Contractor or Sub-Contractor.
9. INSURANCE AND LIABILITY
- 9.1 The Contractor's liability to the City of Iqaluit for claims arising out of this Agreement, or in any way relating to the Services, will be limited to direct damages and to the re-performance, without additional compensation, of any Services not meeting a normal professional standard of care and such liability will, in the aggregate, not exceed the amount of \$1,000,000.00. The limitations of liability will apply, to the extent permitted by law, whether Contractor's liability arises under breach of contract or warranty; tort, including negligence; strict liability; statutory liability; or any other cause of action, and will extend to and include Contractor's directors, officers, employees, insurers, agents and sub-contractor.
 - 9.2 In no event will either party be liable to the other party for indirect or consequential damages including without limitation loss of use or production, loss of profits or business interruption.
 - 9.3 The Contractor shall, without limiting his obligations or liabilities hereto, obtain, maintain and pay for during the period of this agreement, the following insurance with limits not less than those shown:
 - a) Workers' Compensation insurance covering all employees engaged in the work in accordance with the statutory requirements of the Territory or Province having jurisdiction over such employees. If the Contractor is assessed any additional levy, extra assessment or super-assessment by a Workers' Compensation Board as a result of an accident causing injury or death to an employee of the Contractor or any sub-contractor, or due to unsafe working conditions, then such levy or assessment shall be paid by the Contractor at its sole cost and is not reimbursed by the CITY OF IQALUIT.
 - b) Employer's liability insurance with limits not less than \$500,000 for each accidental injury to or death of the Contractor's employees engaged in the work. If Workers' Compensation insurance exists, then in such event, the aforementioned Employer's Liability insurance shall not be required but the Comprehensive General Liability policy referred to in item (d) herein shall contain an endorsement providing for Contingent Employers' Liability insurance.
 - c) Motor Vehicle, water craft and snow craft standard liability insurance covering all vehicles and/or craft owned or non-owned, operated and/or licensed by the Contractor and used by the

INITIALS _____



REQUEST FOR QUOTATION
**CONSTRUCTION SERVICES FOR
 FIRE TRAINING GROUND REPLACEMENT – STEEL STRUCTURE
 ELECTRICAL INSTALLATION**
 2021-RFQ-108



Contractor in the performance of this agreement in an amount not less than one million dollars (\$1,000,000.00) per occurrence for bodily injury, death and damage to property; and with respect to busses limits of not less than one million dollars (\$1,000,000.00) for vehicle hazards and not less than one million dollars (\$1,000,000.00) for Bodily Injury to or death of one or more passengers and loss of or damage to the passengers property in one accident.)

d) Comprehensive General Liability Insurance with limits of not less than **insert value** (inclusive) per occurrence for bodily injury, death and damage to property including loss of use thereof. Such insurance shall include but not be limited to the following terms and conditions:

- Products & Completed Operations Liability *
- Contractor’s Protective Liability
- Blanket Contractual Liability
- Broad Form Property Damage
- Personal Injury Liability
- Cross Liability
- Medical Payments
- Non-owned Automobile Liability *
- Contingent Employers Liability *
- Employees as Additional Insureds *

**WHERE APPLICABLE*

e) Professional Liability Insurance with limits of not less than two hundred fifty thousand dollars (\$250,000.00) per claim and five hundred thousand dollars (\$500,000.00) in the annual aggregate, to cover claims arising out of the rendering of or failure to render any professional service under this contract or agreement.

All policies shall provide that thirty days written notice be given to the CITY OF IQALUIT prior to any cancellations of any such policies.

The Comprehensive General Liability Insurance policies shall name the CITY OF IQALUIT and any permitted sub-contractor’s as additional insureds only with respect to the terms of this contract and shall extend to cover the employees of the insureds hereunder.

The Contractor shall be responsible for any deductibles, exclusions and/or insufficiency of coverage relating to such policies.

The Contractor shall deposit with the CITY OF IQALUIT prior to commencing with the work a certificate of insurance evidencing the insurance(s) required by this clause in a form satisfactory to the CITY OF IQALUIT and with insurance companies satisfactory to the CITY OF IQALUIT.

IN WITNESS WHEREOF the parties hereto have set their hand as of the date and year entered below.

INITIALS _____



REQUEST FOR QUOTATION
**CONSTRUCTION SERVICES FOR
 FIRE TRAINING GROUND REPLACEMENT – STEEL STRUCTURE
 ELECTRICAL INSTALLATION**
 2021-RFQ-108



FOR THE CITY OF IQALUIT:

FOR THE CONTRACTOR:

 Name/Title

 Name/Title

 Signature

 Signature

 Date

 Date

 Witness

 Witness

END OF APPENDIX A

INITIALS _____

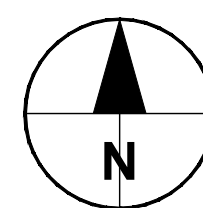
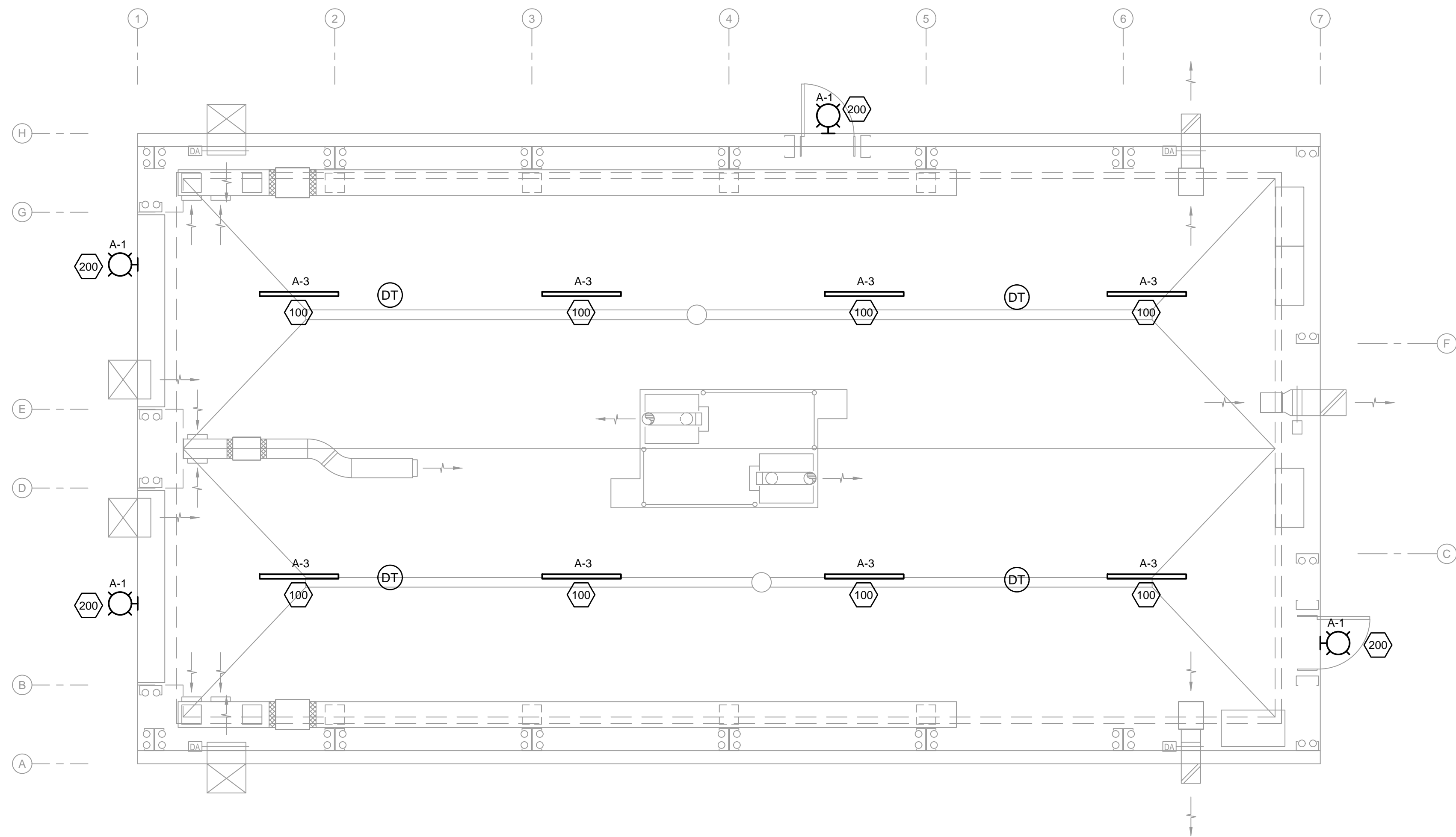
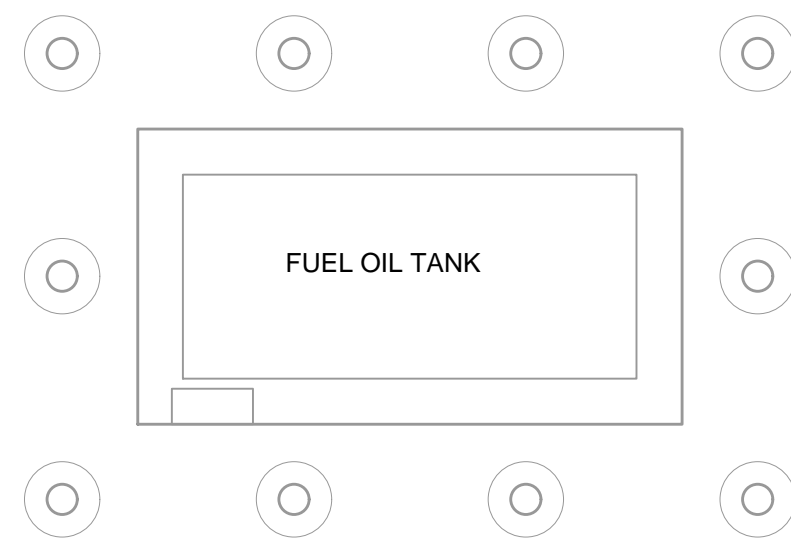

LIGHTING PLAN

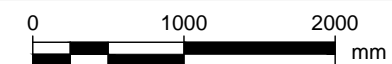

Scale 1:50

ELECTRICAL CONSTRUCTION LEGEND:

- DUPLEX RECEPTACLE
- CORD REEL - 20A
- MOTOR
- DISCONNECT SWITCH
- PANELBOARD
- TELECOMMUNICATIONS WALL OUTLET, V=VOICE, D=DATA (EG. 2D=2 TELECOM CABLE JACKS, 2V=2 VOICE JACKS)
- SURFACE/SUSPENDED LED LIGHT FIXTURE
- WALL LIGHT
- LUMINAIRE TYPE
- DUAL TECHNOLOGY OCCUPANCY SENSOR

CONSTRUCTION NOTES:

1. ELECTRICAL CONTRACTOR TO UPDATE CIRCUITRY ON ELECTRICAL DRAWINGS AT RECORD DRAWING STAGE.
2. ALL CONDUITS TO BE SURFACE MOUNTED.
3. REFER TO MECHANICAL DRAWINGS FOR EXACT LOCATIONS AND REQUIREMENTS FOR MOTOR LOADS AND THERMOSTATS PRIOR TO INSTALLATION OF REQUIRED ELECTRICAL PROVISIONS.
4. COORDINATE EXACT MOUNTING LOCATIONS OF ALL MECHANICAL EQUIPMENT CONTROL MODULES (IE. VFD's, THERMOSTATS, MANUAL MOTOR STARTERS, CONTROL PANELS, ETC.) WITH MECHANICAL PRIOR TO ROUGH-INS.
5. LIGHTS ARE SUSPENDED TO BE AT 4450 mm AFF
6. LIGHTING CONTROL TO BE AUTO ON/VACANCY OFF. LIGHTS TO REMAIN ON UNTIL NO MOVEMENT HAS BEEN DETECTED FOR 30 MINUTES.



PROJECT

**City of Iqaluit
 Fire Department
 Garage**

CLIENT

City of Iqaluit

Building 901, City of Iqaluit, Box 460
 Iqaluit, Nunavut X0A 0H0
 867.979.5600 tel 867.979.5922 fax
 www.city.iqaluit.nu.ca

CONSULTANT

AECOM
 101 18817 Stony Plain Rd NW
 Edmonton, AB T5S 0C2, Canada
 780.486.7000 tel
 www.aecom.com

NOTICE:
 THE EXISTENCE, LOCATION AND ELEVATION OF UTILITIES AND/OR CONCEALED STRUCTURES AT THE PROJECT SITE ARE NOT GUARANTEED BY AECOM CANADA LTD.
 THE CONTRACTOR IS RESPONSIBLE FOR DETERMINING THE EXISTENCE, LOCATION AND ELEVATION OF ALL SUCH UTILITIES AND/OR STRUCTURES AND IS RESPONSIBLE FOR NOTIFYING THE APPROPRIATE COMPANY, DEPARTMENT OR PERSON(S) OF ITS INTENTION TO CARRY OUT ITS OPERATIONS.

REGISTRATION

ISSUE/REVISION

IR	DATE	DESCRIPTION
B	2021/09/09	ISSUED FOR 99% REVIEW
A	07/30/2021	ISSUED FOR 99% REVIEW

KEY PLAN

PROJECT NUMBER

60642509

SHEET TITLE

LIGHTING - FLOOR PLAN

SHEET NUMBER

01-E-1001

This drawing has been prepared for the use of AECOM's client and may not be used, reproduced or relied upon by third parties, except as agreed by AECOM and its client, as required by law or for use by governmental reviewing agencies. AECOM accepts no responsibility, and denies any liability whatsoever, to any party that modifies this drawing without AECOM's express written consent. Do not scale this document. All measurements must be obtained from stated dimensions.

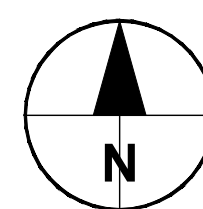
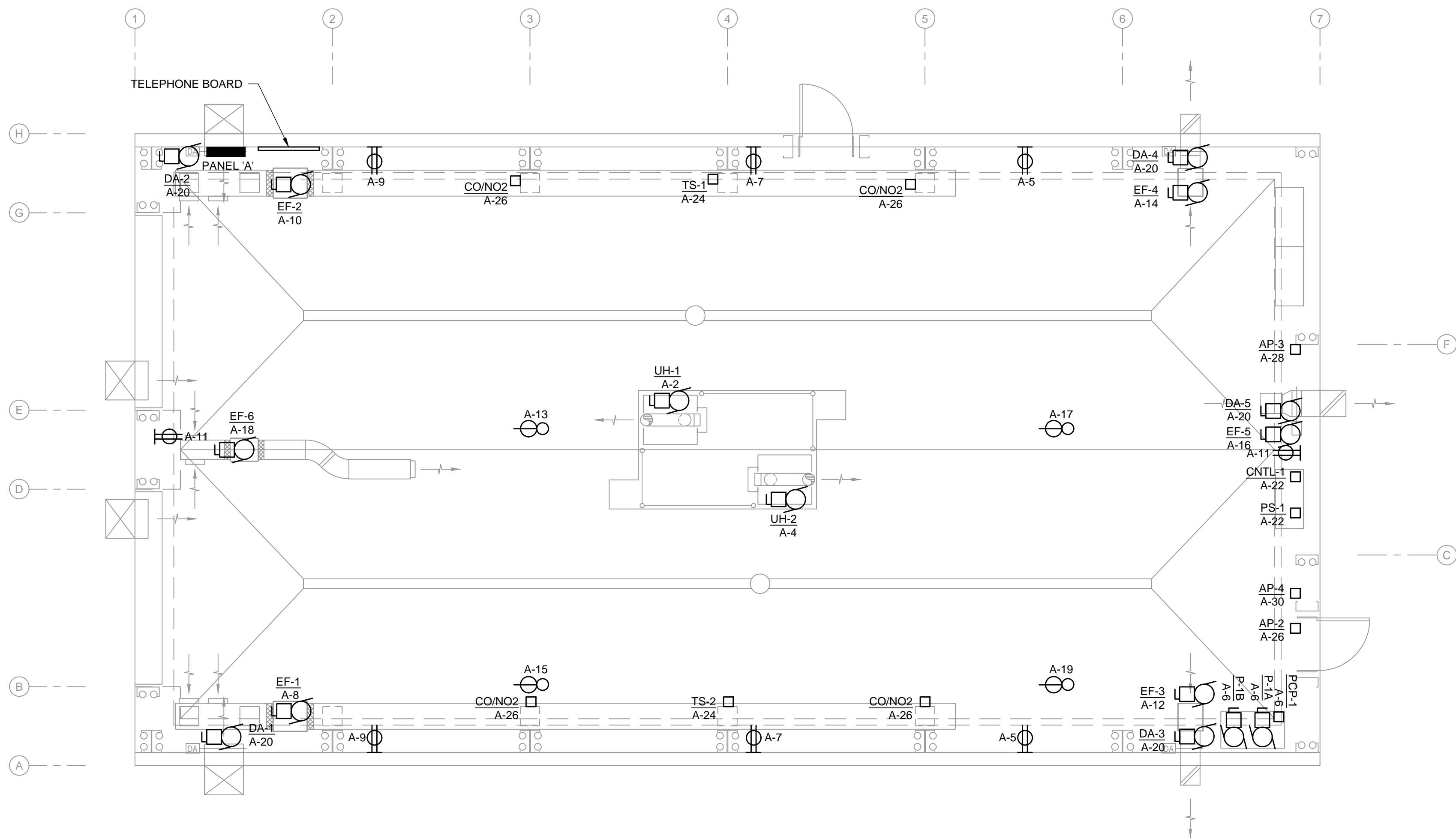
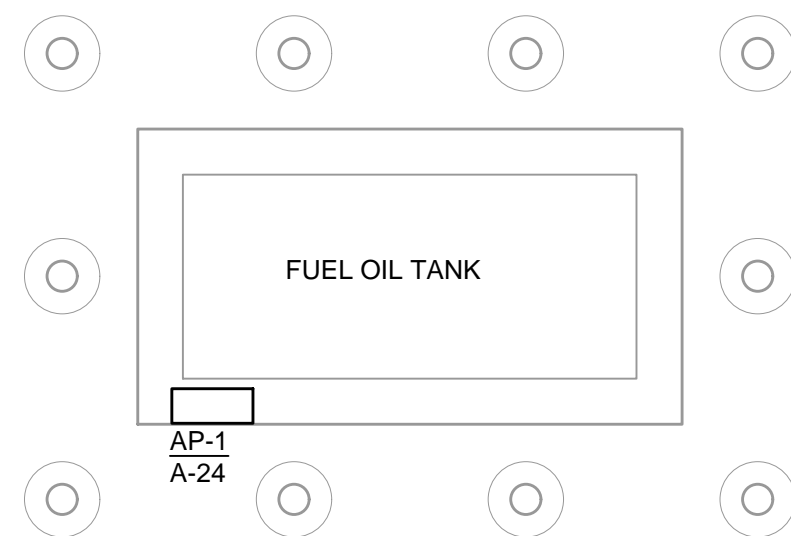





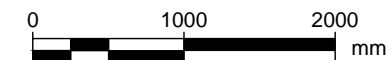





POWER AND SYSTEM PLAN

Scale 1:50



ELECTRICAL CONSTRUCTION LEGEND:

-  DUPLEX RECEPTACLE
-  CORD REEL - 20A
-  MOTOR
-  DISCONNECT SWITCH
-  PANELBOARD
-  TELECOMMUNICATIONS WALL OUTLET, V=VOICE, D=DATA (EG. 2D=2 TELECOM CABLE JACKS, 2V=2 VOICE JACKS)
-  SURFACE/SUSPENDED LED LIGHT FIXTURE
-  WALL LIGHT
-  LUMINAIRE TYPE
-  DUAL TECHNOLOGY OCCUPANCY SENSOR

CONSTRUCTION NOTES:

1. ELECTRICAL CONTRACTOR TO UPDATE CIRCUITRY ON ELECTRICAL DRAWINGS AT RECORD DRAWING STAGE.
2. ALL CONDUITS TO BE SURFACE MOUNTED.
3. REFER TO MECHANICAL DRAWINGS FOR EXACT LOCATIONS AND REQUIREMENTS FOR MOTOR LOADS AND THERMOSTATS PRIOR TO INSTALLATION OF REQUIRED ELECTRICAL PROVISIONS.
4. COORDINATE EXACT MOUNTING LOCATIONS OF ALL MECHANICAL EQUIPMENT CONTROL MODULES (IE. VFD's, THERMOSTATS, MANUAL MOTOR STARTERS, CONTROL PANELS, ETC.) WITH MECHANICAL PRIOR TO ROUGH-INS.
5. LIGHTS ARE SUSPENDED TO BE AT 4450 mm AFF
6. LIGHTING CONTROL TO BE AUTO ON/VACANCY OFF. LIGHTS TO REMAIN ON UNTIL NO MOVEMENT HAS BEEN DETECTED FOR 30 MINUTES.



PROJECT

**City of Iqaluit
 Fire Department
 Garage**

CLIENT

City of Iqaluit

Building 901, City of Iqaluit, Box 460
 Iqaluit, Nunavut X0A 0H0
 867.979.5600 tel 867.979.5922 fax
 www.city.iqaluit.nu.ca

CONSULTANT

AECOM
 101 18817 Stony Plain Rd NW
 Edmonton, AB T5S 0C2, Canada
 780.486.7000 tel
 www.aecom.com

NOTICE:
 THE EXISTENCE, LOCATION AND ELEVATION OF UTILITIES AND/OR CONCEALED STRUCTURES AT THE PROJECT SITE ARE NOT GUARANTEED BY AECOM CANADA LTD.
 THE CONTRACTOR IS RESPONSIBLE FOR DETERMINING THE EXISTENCE, LOCATION AND ELEVATION OF ALL SUCH UTILITIES AND/OR STRUCTURES AND IS RESPONSIBLE FOR NOTIFYING THE APPROPRIATE COMPANY, DEPARTMENT OR PERSON(S) OF ITS INTENTION TO CARRY OUT ITS OPERATIONS.

REGISTRATION

ISSUE/REVISION

U/R	DATE	DESCRIPTION
B	2021/09/09	ISSUED FOR 99% REVIEW
A	07/30/2021	ISSUED FOR 99% REVIEW

KEY PLAN

PROJECT NUMBER

60642509

SHEET TITLE

POWER - FLOOR PLAN

SHEET NUMBER

01-E-1002

This drawing has been prepared for the use of AECOM's client and may not be used, reproduced or relied upon by third parties, except as agreed by AECOM and its client, as required by law or for use by governmental reviewing agencies. AECOM accepts no responsibility, and denies any liability whatsoever, to any party that modifies this drawing without AECOM's express written consent. Do not scale this document. All measurements must be obtained from stated dimensions.

REFER TO LIGHTING PLANS FOR FIXTURE LENGTHS

LAMP TYPE: LED, 5200 LUMENS, 53W, 3500K
 LAMP QTY: -
 MOUNTING: SURFACE OR SUSPENDED
 HOUSING: STEEL, WHITE BAKED ENAMEL
 REFLECTOR: -
 LENS: FROSTED ACRYLIC

SPECIAL REQUIREMENTS:
 120V, 0-10V DIMMING DRIVER <10% THD, C/W WIREGUARD, CSA

Products are listed to establish reference standards. For approval of equivalents refer to General Conditions of specification.

ACCEPTABLE PRODUCTS:
 MANUFACTURER PART No.

METALUX	SNLED SERIES
CFI	FLUXSTREAM LF SERIES
LITHONIA	ZL1D LED SERIES
COLUMBIA LIGHTING	LCL LED SERIES

OR APPROVED EQUIVALENT

LUMINAIRE SCHEDULE

TYPE No.
100

REFER TO LIGHTING PLANS FOR FIXTURE LENGTHS

LAMP TYPE: LED, 4000 LUMENS, 50W, 3000K
 LAMP QTY: -
 MOUNTING: EXTERIOR SURFACE MOUNTED
 HOUSING: CAST ALUMINUM FINISHED COLOR TO MATCH MOUNTING PANEL
 REFLECTOR: -
 LENS: TEMPERED GLASS

SPECIAL REQUIREMENT:
 • 120V
 • SEE TYPE DISTRIBUTION CHART
 • FULL CUTOFF, HOUSE SIDE SHIELDS (LIGHTING CUTOFF PURPOSES) & DARK SKY COMPLIANT
 • IP66 RATED, CSA

Products are listed to establish reference standards. For approval of equivalents refer to General Conditions of specification.

ACCEPTABLE PRODUCTS:
 MANUFACTURER PART No.

MCGRRAW- EDISON	ISS LED SERIES
LITHONIA	MRW LED SERIES
SPAULDING LIGHTING	QSP LED SERIES

OR APPROVED EQUIVALENT

LUMINAIRE SCHEDULE

TYPE No.
200

PANEL 'A'					
DESCRIPTION	BKR.	CIRCUIT NO.	BKR. DESCRIPTION		
LIGHTING - EXTERIOR	1P15A	1	2	1P15A	UNIT HEATER - UH-1
LIGHTING - INTERIOR AND EMERGENCY	1P15A	3	4	1P15A	UNIT HEATER - UH-2
RECEPTACLES - INTERIOR	1P15A	5	6	1P15A	FUEL BOOSTER PUMP PCP-1, P-1A, P-1B
RECEPTACLES - INTERIOR	1P15A	7	8	1P35A	FAN - EF-1
RECEPTACLES - INTERIOR	1P15A	9	10	1P35A	FAN - EF-2
RECEPTACLES - INTERIOR	1P15A	11	12	1P15A	FAN - EF-3
CORD REEL - BAY 1 FIRE TRUCK	1P20A	13	14	1P15A	FAN - EF-4
CORD REEL - BAY 2 FIRE TRUCK	1P20A	15	16	1P35A	FAN - EF-5
CORD REEL - BAY 1 AMBULANCE	1P20A	17	18	1P15A	FAN - EF-6
CORD REEL - BAY 2 AMBULANCE	1P20A	19	20	1P15A	DAMPER ACTUATORS DA-1, DA-2, DA-3, DA-4, DA-5
EXTERIOR LIGHTING CONTROL	1P15A	21	22	1P15A	MECHANICAL CONTROL POWER PS-1, CNTL-1
SPARE	1P20A	23	24	1P15A	ALARM PANEL AP-1 FUEL OIL FILL ALARM PANEL
SPARE	1P20A	25	26	1P15A	ALARM PANEL AP-2 FUEL OIL LEAK PANEL
SPARE	1P20A	27	28	1P15A	ALARM PANEL AP-3 CO/NO2 MONITORS
SPARE	1P20A	29	30	1P15A	ALARM PANEL AP-4 MONITOR AND AUTODIALER
SPARE	1P15A	31	32	1P15A	SPARE
SPARE	1P15A	33	34	1P15A	SPARE
SPARE	1P15A	35	36	1P15A	SPARE
SPARE	1P15A	37	38	1P15A	SPARE
SPARE	1P15A	39	40	1P15A	SPARE
SPARE	1P15A	41	42	1P15A	SPARE
TOTAL				TOTAL	
MAINS:	225A	VOLTS:	120/240V		
BREAKER:	SERVICE ENTRANCE RATED: 100A	LOCATION:	INTERIOR GARAGE WALL		
MOUNTING:	SURFACE				

MOTOR No.	LOCATION	DESCRIPTION	MOTOR SCHEDULE														NOTES				
			MOTOR SIZE					CIRCUIT	BREAKER	FEEDER	CONDUIT	STARTER	SIZE	UNFUSED DISCONNECT	PL	KEYED		AUXILL. DEVICES			
			HP	KW	VOLTS	PHASE	FLA(A)											H.O.A.	N.O.	N.C.	
UH-1	GARAGE	UNIT HEATER	1/3	120	1	7.2	A-2	1P15A	2#12	21mmC											WALL MOUNTED THERMOSTAT.
UH-2	GARAGE	UNIT HEATER	1/3	120	1	7.2	A-4	1P15A	2#12	21mmC											WALL MOUNTED THERMOSTAT.
P-1A P-1B	GARAGE	FUEL BOOSTER PUMPS	FRAC.	120	1	2.2	A-6	1P15A	2#12	21mmC	MANUAL										CONTROLLED BY PCP-1
EF-1	GARAGE	CONSTANT RECIRC. FAN	3/4	.56	120	1	13.8	A-8	1P35A	2#12	21mmC	VSD									NOTE 1, 2
EF-2	GARAGE	CONSTANT RECIRC. FAN	3/4	.56	120	1	13.8	A-10	1P35A	2#12	21mmC	VSD									NOTE 1, 2
EF-3	GARAGE	OCCUPIED EXHAUST FAN	1/6	.124	120	1	4.4	A-12	1P15A	2#12	21mmC	VSD									NOTE 1, 2, 3
EF-4	GARAGE	CONSTANT EXHAUST FAN	1/6	.124	120	1	4.4	A-14	1P15A	2#12	21mmC	VSD									NOTE 1, 2
EF-5	GARAGE	CO/NO2 FLUSH EXHAUST FAN	3/4	.56	120	1	13.8	A-16	1P35A	2#12	21mmC	VSD									NOTE 1, 2, 4
EF-6	GARAGE	CO/NO2 SWEEP FAN	1/4	.187	120	1	5.8	A-18	1P15A	2#12	21mmC	VSD									NOTE 1, 2, 4

NOTES:

- LOCATE PILOT LIGHT DISCONNECT NEXT TO UNIT
- STARTER SUPPLIED WITH UNIT
- RUNS WITH LIGHTS ON AND HIGH TEMP (TS-6)
- STARTS ON CO/NO2 ALARM AND RUNS FOR 5-10 MINUTES (ADJUSTABLE)

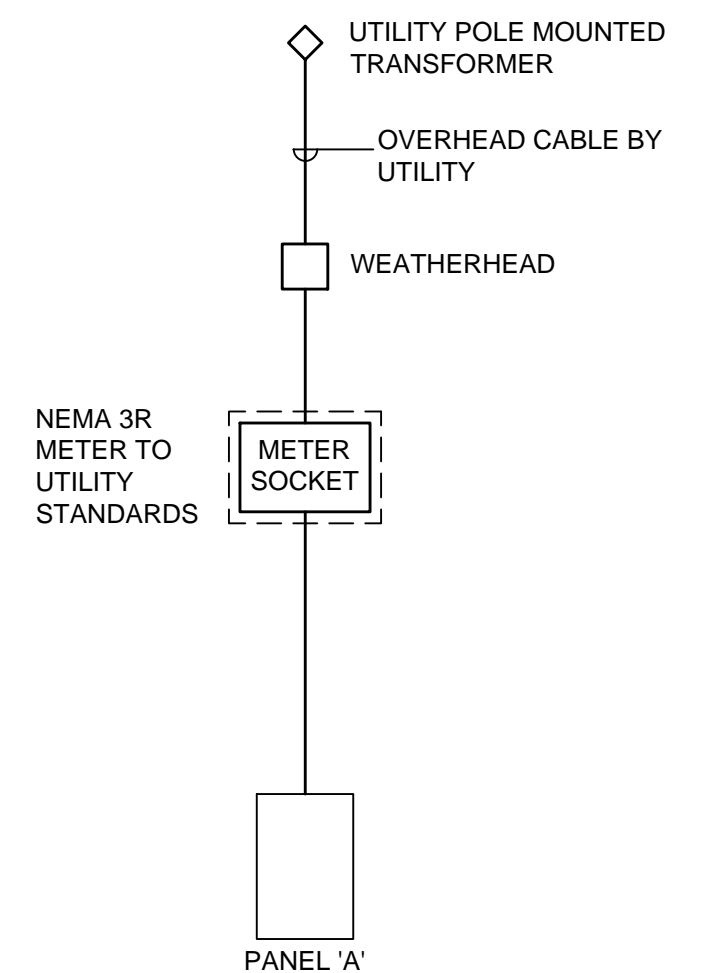
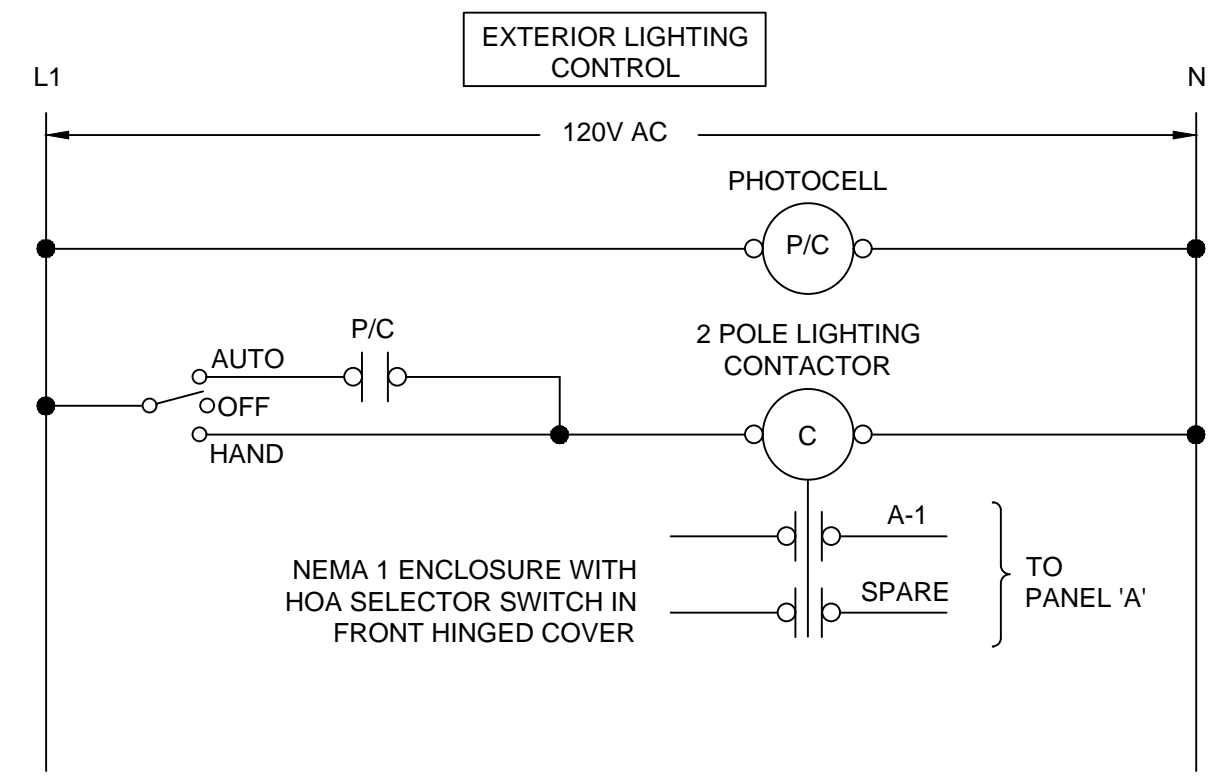

PROJECT
 City of Iqaluit
 Fire Department
 Garage

CLIENT
 City of Iqaluit
 Building 901, City of Iqaluit, Box 460
 Iqaluit, Nunavut X0A 0H0
 867.979.5600 tel 867.979.5922 fax
 www.city.iqaluit.nu.ca

CONSULTANT
 AECOM
 101 18817 Stony Plain Rd NW
 Edmonton, AB T5S 0C2, Canada
 780.486.7000 tel
 www.aecom.com

NOTICE:
 THE EXISTENCE, LOCATION AND ELEVATION OF UTILITIES AND/OR CONCEALED STRUCTURES AT THE PROJECT SITE ARE NOT GUARANTEED BY AECOM CANADA LTD.
 THE CONTRACTOR IS RESPONSIBLE FOR DETERMINING THE EXISTENCE, LOCATION AND ELEVATION OF ALL SUCH UTILITIES AND/OR STRUCTURES AND IS RESPONSIBLE FOR NOTIFYING THE APPROPRIATE COMPANY, DEPARTMENT OR PERSON(S) OF ITS INTENTION TO CARRY OUT ITS OPERATIONS.

REGISTRATION

ISSUE/REVISION

I/R	DATE	DESCRIPTION
B	2021/09/09	ISSUED FOR 99% REVIEW
A	07/30/2021	ISSUED FOR 99% REVIEW

KEY PLAN

PROJECT NUMBER
 60642509

SHEET TITLE
 ELECTRICAL - PANEL, MOTOR & LUMINAIRE SCHEDULES

SHEET NUMBER
 01-E-1003

This drawing has been prepared for the use of AECOM's client and may not be used, reproduced or relied upon by third parties, except as agreed by AECOM and its client, as required by law or for use by governmental reviewing agencies. AECOM accepts no responsibility, and denies any liability whatsoever, to any party that modifies this drawing without AECOM's express written consent. Do not scale this document. All measurements must be obtained from stated dimensions.

ELECTRICAL SPECIFICATIONS: GENERAL

- 1.1 GENERAL
- WORK TO INCLUDE THE FURNISHING OF ALL LABOUR AND MATERIALS UNLESS SPECIFIED OTHERWISE TO COMPLETE AND PUT INTO OPERATING CONDITION ALL ELECTRICAL SYSTEMS AS INDICATED ON THE DRAWINGS AND SPECIFIED HEREIN.
 - INTENT OF DRAWINGS AND SPECIFICATIONS IS TO INCLUDE ALL LABOUR, PRODUCTS AND SERVICES NECESSARY FOR COMPLETE WORK, TESTED AND READY FOR OPERATION.
 - SYMBOLS USED TO REPRESENT VARIOUS ELECTRICAL DEVICES OFTEN OCCUPY MORE SPACE ON DRAWING THAN ACTUAL DEVICE DOES WHEN INSTALLED. IN SUCH INSTANCES, DO NOT SCALE LOCATIONS OF DEVICES FROM ELECTRICAL SYMBOLS. INSTALL DEVICES WITH PRIMARY REGARD FOR USAGE OF WALL SPACE, CONVENIENCE OF OPERATION AND GROUPING OF DEVICES.
 - THESE SPECIFICATIONS AND THE DRAWINGS AND SPECIFICATIONS OF ALL OTHER DIVISIONS SHALL BE CONSIDERED AS AN INTEGRAL PART OF THE ACCOMPANYING DRAWINGS. ANY ITEM OR SUBJECT OMITTED FROM EITHER THE SPECIFICATIONS OR THE DRAWINGS BUT WHICH IS MENTIONED OR REASONABLY SPECIFIED IN AND BY THE OTHERS, SHALL BE CONSIDERED AS PROPERLY AND SUFFICIENTLY SPECIFIED AND SHALL BE PROVIDED.
 - PROVIDE ALL MINOR ITEMS AND WORK NOT SHOWN OR SPECIFIED BUT WHICH ARE REASONABLY NECESSARY TO COMPLETE THE WORK.
 - IF DISCREPANCIES OR OMISSIONS IN DRAWINGS OR SPECIFICATIONS ARE FOUND, OR IF INTENT OR MEANING IS NOT CLEAR, ADVISE THE CONSULTANT FOR CLARIFICATION BEFORE SUBMITTING TENDER.
 - RESPONSIBILITY TO DETERMINE WHICH DIVISION PROVIDES VARIOUS PRODUCTS AND WORK RESTS WITH THE CONTRACTOR. ADDITIONAL COMPENSATION WILL NOT BE CONSIDERED BECAUSE OF DIFFERENCES IN INTERPRETATION OF SPECIFICATIONS.
 - EXECUTE ALL WORK IN COMPETENT MANNER AND TO PRESENT ACCEPTABLE APPEARANCE WHEN COMPLETED.
 - EMPLOY COMPETENT SUPERVISOR AND SUFFICIENT NUMBER OF LICENSED TRADESMEN TO COMPLETE WORK IN REQUIRED TIME.
- 1.2 DRAWINGS AND SPECIFICATIONS
- DRAWINGS AND SPECIFICATIONS ARE COMPLEMENTARY EACH TO THE OTHER AND WHAT IS CALLED FOR BY ONE TO BE BINDING AS IF CALLED FOR BY BOTH.
 - SHOULD ANY DISCREPANCY APPEAR BETWEEN DRAWINGS AND SPECIFICATIONS WHICH LEAVES ELECTRICAL TRADE IN DOUBT AS TO TRUE INTENT AND MEANING, OBTAIN RULING BEFORE SUBMITTING TENDER. IF THIS IS NOT DONE, IT WILL BE ASSUMED THAT THE MOST EXPENSIVE ALTERNATE HAS BEEN FIGURED.
- 1.3 EXAMINATION OF OTHER DRAWINGS
- THIS CONTRACTOR TO EXAMINE CAREFULLY STRUCTURAL, ARCHITECTURAL AND MECHANICAL DRAWINGS AND WORK OF OTHER TRADES AND SATISFY HIMSELF THAT THE WORK UNDER THIS CONTRACT CAN BE SATISFACTORILY CARRIED OUT WITHOUT CHANGES TO THE BUILDING AS SHOWN ON THE PLANS. SHOULD ANY DIFFICULTY ARISE SHOWING CONFLICT WITH, OR REQUIRING ADDITIONAL WORK BEYOND THE WORK OF THESE DRAWINGS, BRING THIS MATTER TO THE ATTENTION OF THE CONSULTANT BEFORE SUBMITTING TENDER.
- 1.4 UNIFORMITY OF EQUIPMENT
- UNLESS OTHERWISE SPECIFIED, UNIFORMITY OF MANUFACTURE TO BE MAINTAINED FOR ANY PARTICULAR ITEM THROUGHOUT.
- 1.5 STANDARDS OF MATERIAL AND WORKMANSHIP
- ALL MATERIALS TO BE NEW AND OF THE QUALITY SPECIFIED AND CONFORM TO THE STANDARDS OF CSA. WHERE EQUIPMENT OR MATERIALS ARE SPECIFIED BY TECHNICAL DESCRIPTION ONLY, THEY SHALL BE OF THE BEST COMMERCIAL QUALITY OBTAINABLE FOR THE PURPOSE.
 - ALL WORK TO BE EXECUTED IN A NEAT AND WORKMANLIKE MANNER BY QUALIFIED TRADESMEN. ELECTRICAL TRADE TO KEEP A COMPETENT FOREMAN AND NECESSARY ASSISTANTS ON THE JOB DURING THE PROGRESS OF THE WORK.
 - PRODUCTS AND MATERIALS REFERRED TO IN SPECIFICATIONS BY TRADE NAMES, MANUFACTURER'S NAME AND CATALOGUE REFERENCE ARE THOSE WHICH SHALL BE USED AS BASIS FOR TENDER.
 - DESIGN HAS BEEN BASED ON USE OF SPECIFIED PRODUCT.
- 1.6 RECORD PLANS
- THE CONSULTANT WILL FURNISH TO THE ELECTRICAL TRADE ONE SET OF PRINTS TO BE USED FOR RECORD PURPOSES. ALL REVISIONS MADE ON SITE DURING CONSTRUCTION TO BE ACCURATELY RECORDED.
- 1.7 SHOP DRAWINGS
- ELECTRICAL TRADE TO SUBMIT TO THE CONSULTANT FOR REVIEW, SHOP DRAWINGS OF ELECTRICAL COMPONENTS AS INDICATED.
 - ALL DRAWINGS TO BE SUBMITTED ELECTRONICALLY IN PDF FORMAT FOR REVIEW BY CONSULTANT. SUBMIT ADDITIONAL COPIES FOR APPROVAL AS MAY BE REQUIRED.
 - CONSULTANT'S REVIEW OF SHOP DRAWINGS TO BE FOR GENERAL DESIGN ONLY AND WILL NOT RELIEVE ELECTRICAL TRADE OR SUPPLIERS FROM RESPONSIBILITY FOR ERRORS, PROPER FITTING, CONSTRUCTION OF WORK AND FURNISHING OF MATERIALS. REVIEW WILL NOT BE CONSTRUED AS APPROVING DEPARTURES FROM CONTRACT DOCUMENT REQUIREMENTS IF SUCH DEPARTURES ARE NOT SPECIFICALLY NOTED. ELECTRICAL TRADE TO BE RESPONSIBLE FOR VERIFYING ALL DIMENSIONS.
- 1.8 GUARANTEE WARRANTY
- FURNISH A WRITTEN GUARANTEE WARRANTY COUNTERSIGNED AND GUARANTEED BY GENERAL CONTRACT TRADE STATING:
 - THAT ALL WORK EXECUTED UNDER THIS CONTRACT WILL BE FREE FROM DEFECTS OF MATERIAL AND WORKMANSHIP FOR A PERIOD OF 1 YEAR FROM DATE OF FINAL ACCEPTANCE.
- 1.9 SETTING OUT OF THE WORK
- ELECTRICAL TRADE TO BE RESPONSIBLE FOR CORRECTING ALL WORK COMPLETED CONTRARY TO INTENT OF DRAWINGS AND SPECIFICATIONS AND BEAR ALL COST FOR SAME. WHERE INTENT OF DRAWINGS AND SPECIFICATIONS IS NOT CLEAR, OBTAIN CLARIFICATION BEFORE PROCEEDING WITH WORK.
 - ELECTRICAL TRADE TO GIVE WORK HIS PERSONAL SUPERVISION, LAY OUT HIS OWN WORK, DO ALL NECESSARY LEVELLING AND MEASURING OR EMPLOY A COMPETENT CONSULTANT TO DO SO. FIGURES, FULL SIZE AND DETAIL DRAWINGS TO TAKE PRECEDENCE OVER SCALE MEASUREMENTS.
 - WHERE ANY EQUIPMENT SUPPLIED BY ELECTRICAL TRADE MUST BE BUILT IN WITH WORK OF OTHER CONTRACTORS, THIS CONTRACTOR TO BE RESPONSIBLE FOR SUPPLYING OF EQUIPMENT TO BE BUILT IN OR MEASUREMENTS TO ALLOW NECESSARY OPENINGS TO BE LEFT SO AS NOT TO HOLD UP WORK.
 - ELECTRICAL TRADE TO BE RESPONSIBLE FOR ANY DAMAGE CAUSED TO OWNER OR ANY OTHER TRADE BY IMPROPER LOCATION OR CARRYING OUT OF HIS WORK.
 - PROVIDE 3 mm THICK PLASTIC LAMACOID NAME PLATES, BLACK FACE, WHITE CORE, MECHANICALLY ATTACHED WITH SELF TAPPING SCREWS, 6 mm HIGH LETTERING, TO BE ATTACHED TO FRONT FACE OF ALL NEW ELECTRICAL EQUIPMENT.
 - MAINTAIN SEPARATION BETWEEN ELECTRICAL WIRING SYSTEM AND BUILDING PIPING, DUCTWORK, ETC. SO THAT WIRING SYSTEM IS ISOLATED (EXCEPT AT APPROVED CONNECTIONS TO SUCH SYSTEMS) TO PREVENT GALVANIC CORROSION.
 - DO NOT SUPPORT WIRING FROM PIPES, DUCTWORK, CEILING HANGARS ETC.
 - ALL CONDUIT AND CABLE ENTRIES THROUGH OUTSIDE WALLS OF BUILDINGS, THROUGH PARTITION WALLS SEPARATING ELECTRICAL ROOMS FROM OTHER AREAS, THROUGH FIRE SEPARATIONS, AND THROUGH FLOORS OR ROOFS ABOVE GRADE TO BE SEALED TO PREVENT PASSAGE OF MOISTURE, DUST, GASSES, FLAME, OR TO MAINTAIN PRESSURIZATION.

1.10 EXAMINATION OF THE SITE

- PRIOR TO SUBMITTING TENDER, IT IS STRONGLY RECOMMENDED THAT THE ELECTRICAL TRADE CAREFULLY EXAMINE THE SITE AND ASCERTAIN ALL CONDITIONS WHICH MAY AFFECT HIS TRADE. NO EXTRAS WILL BE ALLOWED FOR WORK RESULTING FROM CONDITIONS THAT WOULD HAVE BEEN EVIDENT UPON A THOROUGH EXAMINATION OF SITE.

1.11 CUTTING AND PATCHING

- GENERAL TRADE WILL BE RESPONSIBLE FOR ALL CUTTING AND PATCHING REQUIRED FOR ELECTRICAL INSTALLATION. STRUCTURAL MEMBERS MUST NOT BE CUT WITHOUT CONSENT OF THE CONSULTANT.
- WHERE WORK BY ELECTRICAL TRADE DAMAGES WORK OF OTHER TRADES, ELECTRICAL TRADE TO REPAIR AND MAKE GOOD SUCH DAMAGE TO SATISFACTION OF TRADE CONCERNED AND THE CONSULTANT.

1.12 CLEANUP

- ELECTRICAL TRADE AND HIS SUBTRADES TO AT ALL TIMES DURING CONSTRUCTION, KEEP SITE FREE OF ALL DEBRIS, BOXES, PACKING, ETC., RESULTING FROM WORK OF THIS TRADE.
- UPON COMPLETION OF WORK, ELECTRICAL INSTALLATION TO BE LEFT IN A CLEAN AND FINISHED CONDITION TO SATISFACTION OF THE CONSULTANT.

1.13 CODES, PERMITS AND INSPECTION

- COMPLY WITH ALL LAWS, ORDINANCES, RULES, REGULATIONS, CODES AND ORDERS OF ALL AUTHORITIES HAVING JURISDICTION RELATING TO THIS WORK.
- COMPLY WITH ALL RULES OF CANADIAN ELECTRICAL CODE, CSA STANDARD C22.1 AND APPLICABLE BUILDING CODES. DO UNDERGROUND SYSTEMS IN ACCORDANCE WITH CAN/CSA-C22.3 NO. 7 EXCEPT WHERE SPECIFIED OTHERWISE.
- GIVE ALL REQUIRED NOTICES, SUBMIT DRAWINGS, OBTAIN ALL PERMITS, LICENSES AND CERTIFICATES AND PAY ALL FEES REQUIRED FOR THIS WORK.
- FURNISH CERTIFICATE OF FINAL INSPECTION AND APPROVALS FROM INSPECTION AUTHORITY TO CONSULTANT.

1.14 MECHANICAL EQUIPMENT AND STARTERS

- UNLESS SPECIFIED OTHERWISE, ELECTRICAL TRADE TO SUPPLY AND INSTALL ALL CONDUIT AND WIRE, FITTINGS AND CONNECTIONS FOR ALL MECHANICAL EQUIPMENT. MOTOR PROTECTION SWITCHES COMPLETE WITH OVERLOAD RELAYS, ETC. TO BE SUPPLIED AND INSTALLED BY ELECTRICAL TRADE. ELECTRICAL TRADE TO CONFIRM WITH MECHANICAL TRADE SIZE, CHARACTERISTICS AND LOCATIONS OF ALL MECHANICAL EQUIPMENT BEFORE INSTALLATION OF CONDUIT, OUTLETS, HEATERS, ETC.
- WIRE AND LEAVE IN OPERATION ALL ELECTRICALLY OPERATED EQUIPMENT SUPPLIED UNDER ALL CONTRACTS RELATED TO THIS PROJECT. ALL CONTROL WIRING FOR CONTROL CIRCUITS APPLICABLE TO EQUIPMENT REGARDLESS OF VOLTAGE SHALL BE PROVIDED BY ELECTRICAL CONTRACTOR. CONTROL CIRCUITS MAY VARY WITH DIFFERENT MANUFACTURERS OF EQUIPMENT. VERIFY ALL CONTROL CIRCUITS WITH SUPPLIERS OF EQUIPMENT AND MAKE ANY CORRECTIONS THAT MAY BE REQUIRED.

1.15 TESTS

- ALL PORTIONS OF ELECTRICAL WORK TO BE TESTED AND CHECKED FOR SATISFACTORY OPERATION.

1.16 MOUNTING HEIGHTS

- UNLESS CONFLICT EXISTS, USE THE FOLLOWING AS MOUNTING HEIGHTS FROM FINISHED FLOORS TO CENTRE OF DEVICE.

RECEPTACLES	900 mm
RECEPTACLES ABOVE COUNTERS	175 mm
DATA AND TELECOM OUTLETS	300 mm
LIGHT SWITCHES	1200 mm
PANELBOARDS, STARTERS, AND DISCONNECTS (TO TOP OF COVER)	2000 mm

1.17 CONDUIT

- ALL WIRE AND CABLE TO BE INSTALLED IN CONDUIT WHERE INDICATED.
- SURFACE MOUNTED CONDUITS TO BE INSTALLED PARALLEL TO STRUCTURAL LINES AND WHERE BENDS OCCUR IN PARALLEL RUNS, THEY SHALL BE CONCENTRIC. UTILIZE 2 HOLE CONDUIT STRAPS FOR INDIVIDUAL CONDUIT RUNS. INSTALL CONDUITS ON UNISTRUT RACK WHERE GROUPED. SUPPORT LOAD IN COMPLIANCE WITH CEC.
- FLEXIBLE CONDUIT CONNECTIONS TO MOTORS, CONTROL, ETC., TO BE FLEXIBLE PLASTIC JACKETED, SEAL TIGHT OR APPROVED EQUAL. FLEXIBLE CONDUIT CONNECTIONS ARE REQUIRED TO ALL MOTORS FROM STUB-UPS OR JUNCTION BOXES.

1.18 WIRE AND CABLE

- ALL BUILDING WIRING TO BE 98 % CONDUCTIVITY COPPER, 600 V, RW90 X-LINK.
- MINIMUM CONDUCTOR SIZE #12 AWG TO BE USED FOR MOTOR OR LIGHTING BRANCH CIRCUIT WORK.
- ALL CONDUCTORS TO BE COLOR CODED THROUGHOUT IN ACCORDANCE WITH THE FOLLOWING:
 - EQUIPMENT GROUNDING CONDUCTOR - GREEN
 - NEUTRAL CONDUCTOR - WHITE
 - 120/240 V PHASE WIRES - RED AND BLACK

1.19 BUILDING WIRING

- ARMOURED CABLES: CONDUCTORS: INSULATED, COPPER, SIZE AS INDICATED. MINIMUM CONDUCTORS SIZE TO BE #12 AWG OR AS SHOWN OR REQUIRED BY THE ELECTRICAL INSTALLATION. TYPE: AC90
- GROUP CABLES WHEREVER POSSIBLE AND INSTALL CONCEALED IN BUILDING CEILING AND WALL CONSTRUCTION. TERMINATE CABLES WITH MANUFACTURED WIRE AND BOX CONNECTORS SPECIFICALLY SUITED FOR SUCH USE. PROVIDE CABLE SUPPORT AND FASTENERS IN ACCORDANCE WITH CEC REQUIREMENTS. EXERCISE CARE IN STRIPPING INSULATION FROM WIRE. DO NOT NICK CONDUCTORS.

1.20 OUTLET BOXES

- BOXES: HOT DIP GALVANIZED, CONFORMING TO CSA REQUIREMENTS.
- BOXES FOR CEILING, NO. 54151 BOX, OTHERWISE NO. 52171 OR NO. 72171 BOX AS PER CODE REQUIREMENTS.
- BOXES FOR SURFACE MOUNTED EQUIPMENT: USE CAST ALUMINIUM FSU TYPE WITH THREADED INSERTS AND INTERNAL MOUNTING PROVISIONS.
- ALL OUTLET BOXES TO BE FLUSH MOUNTED EXCEPT AS SPECIFIED.
- NO SECTIONAL OR HANDY BOXES ALLOWED.

1.21 LOCATION OF OUTLETS

- THE CONSULTANT RESERVES THE RIGHT TO CHANGE LOCATION OF OUTLETS TO WITHIN 3 m OF POINTS INDICATED ON PLANS WITHOUT EXTRA CHARGE PROVIDING CONTRACTOR IS ADVISED BEFORE INSTALLATION IS MADE.

1.22 PULLBOXES

- SUPPLY AND INSTALL PULLBOXES AS REQUIRED TO SUIT JOB CONDITIONS. PULLBOXES TO CONFORM TO CANADIAN ELECTRICAL CODE REQUIREMENTS AND BE FINISHED IN ENAMEL OVER CORROSION-RESISTANT PRIMER WITH SCREW-ON OR HINGED COVER. IN REMOVABLE CEILING AREAS, PULLBOXES ARE TO BE INSTALLED ABOVE THE CEILING.

1.23 SWITCHES AND RECEPTACLES

- LINE VOLTAGE SWITCHES TO BE RATED 15 A, 120 V, WHITE HANDLE, HUBBELL 1201-1 OR EQUAL. TWO POLE, 3 WAY AND 4 WAY SWITCHES TO BE OF MATCHING TYPE.
- STANDARD RECEPTACLES TO BE WHITE, HUBBELL 5252-1 OR EQUAL.
- USE SURFACE MOUNT STYLE STAINLESS STEEL 1 mm THICK COVERPLATES ON ALL WIRING DEVICES UNLESS OTHERWISE SPECIFIED.
- FOR ALL RECEPTACLES OTHER THAN STANDARD 15 A DUPLEX RECEPTACLES, PROVIDE LAMICOID NAMETAGS GIVING AMP RATING, PHASE AND VOLTAGE.

1.24 SUPPORTS

- ALL SURFACE CONDUITS, ELECTRICAL EQUIPMENT, ETC., TO BE SECURELY AND ADEQUATELY SUPPORTED.
- WHERE INSERTS ARE REQUIRED IN CONCRETE, EXPANSION INSERTS, LEAD INSERTS OR PLASTIC INSERTS TO BE USED IN DRILLED HOLES. SHOT DRIVEN PINS MAY BE USED IN STRUCTURAL CONCRETE ONLY WITH THE PERMISSION OF THE CONSULTANT.

1.25 GROUNDING

- SUPPLY AND INSTALL COMPLETE GROUNDING SYSTEM AS REQUIRED BY CANADIAN ELECTRICAL CODE AND ELECTRICAL INSPECTION DEPARTMENT. ALL COMPONENTS TO BE SECURELY AND ADEQUATELY GROUNDED AND WHERE REQUIRED TO ACCOMPLISH THIS, GROUNDING JUMPERS, GROUNDING STUDS AND BUSHINGS TO BE USED.
- INSTALL A GROUND CONDUCTOR IN ALL CONDUITS.

1.26 PANELS

- PROVIDE NEW PANEL AS INDICTED. NEW PANEL TO BE SURFACE MOUNTED AS SHOWN, 120 / 240 V, 225 A, SINGLE PHASE, 3 WIRE WITH COPPER BUSSING AND BOLT IN PLACE BREAKERS. PANEL TO BE COMPLETE WITH SERVICE ENTRANCE RATED 100A MAIN BREAKER. PROVIDE TYPEWRITTEN DIRECTORY FOR PANEL.
- NEW BREAKERS TO BE BOLT IN PLACE MOLDED CASE CIRCUIT BREAKERS AS INDICATED WITH THERMAL AND MAGNETIC TRIP AND TRIP FREE POSITIONS SEPARATE FROM EITHER THE "ON" OR THE "OFF" POSITION. TWO POLE BREAKERS TO HAVE A COMMON SIMULTANEOUS TRIP.

1.27 LIGHTING LUMINAIRES

- ELECTRICAL TRADE TO SUPPLY AND INSTALL ALL LIGHTING LUMINAIRES COMPLETE WITH LAMPS, MOUNTING BRACKETS, BALLASTS AND ALL NECESSARY ACCESSORIES IN ACCORDANCE WITH THE LUMINAIRE TYPES SHOWN.
- EXCEPT WHERE OTHERWISE NOTED, BALLASTS TO BE 120 VAC SUPPLY. BALLASTS TO MEET THE STANDARDS OF THE ELECTRICAL TESTING LABORATORY AND CERTIFIED BALLASTS MANUFACTURES ASSOCIATION. ALL BALLASTS TO BE PROVIDED WITH THERMAL PROTECTION OF THE NON RE-SETTING TYPE TO LATEST CSA STANDARDS.

1.28 EXIT LIGHTING

- EXIT LIGHTS: STEEL HOUSING, WHITE FINISH, LED-2W LAMP,120V, 25 YEARS OF CONTINUOUS OPERATION, RUNNING MAN SNAP IN PLACE UNIVERSAL FACE, DIRECTIONAL ARROWS AS REQUIRED. GREEN IN COLOR. SUITABLE FOR CONNECTION TO 12 VDC EMERGENCY SOURCE, UNIVERSAL MOUNTING, C860 CERTIFIED. ACCEPTABLE PRODUCTS: AIMLITE, LUMACELL, STANPRO, SURELITE.

1.29 EMERGENCY LIGHTING

- SUPPLY AND INSTALL BATTERY POWER EMERGENCY LIGHTING WHERE SHOWN ON THE DRAWINGS. LIGHTS ARE TO SWITCH "ON" AUTOMATICALLY IN THE EVENT OF FAILURE OF NORMAL POWER, AND "OFF" ON RESTORATION OF POWER. THE BATTERIES SHALL BE AUTOMATICALLY RECHARGED FROM A 120 VAC SUPPLY.
- SUPPLY VOLTAGE: 120 V, AC, OUTPUT VOLTAGE: 12 V DC, OPERATING TIME: 30 MIN.
- LAMP HEADS: 345° HORIZONTAL AND 180° VERTICAL ADJUSTMENT. LAMP TYPE: LED.
- INSTALL SIMPLEX RECEPTACLE ADJACENT TO UNIT AND CONNECT TO 1Ø, 120V UNSWITCHED AREA LIGHTING CIRCUIT.
- WIRING FROM UNITS TO REMOTE HEADS AND/OR EXIT LIGHTS SHALL BE SIZED TO PREVENT VOLTAGE DROP OF MORE THAN 5%.

1.30 PHONE SYSTEM

- SUPPLY AND INSTALL TELEPHONE BACKBOARD FOR MOUNTING OF SERVICE EQUIPMENT.
- SUPPLY AND INSTALL TELEPHONE LINE FROM SERVICE EQUIPMENT LOCATION TO ADJACENT AUTO-DIALLER.
- CABLES SHALL BE IDENTIFIED BY A SELF-ADHESIVE LABEL IN ACCORDANCE WITH THE SYSTEM DOCUMENTATION SECTION OF THIS SPECIFICATION.
- THE CONTRACTOR SHALL WARRANT THE CABLING SYSTEM AGAINST DEFECTS IN WORKMANSHIP FOR A PERIOD OF ONE YEAR FROM THE DATE OF SYSTEM ACCEPTANCE. THE WARRANTY SHALL COVER ALL LABOUR AND MATERIALS NECESSARY TO CORRECT A FAILED PORTION OF THE SYSTEM AND TO DEMONSTRATE PERFORMANCE WITHIN THE ORIGINAL INSTALLATION SPECIFICATIONS AFTER REPAIRS ARE ACCOMPLISHED. THIS WARRANTY SHALL BE PROVIDED AT NO ADDITIONAL COST TO THE OWNER.

AECOM**PROJECT****City of Iqaluit
Fire Department
Garage****CLIENT****City of Iqaluit**

Building 901, City of Iqaluit, Box 460
Iqaluit, Nunavut X0A 0H0
867.979.5600 tel 867.979.5922 fax
www.city.iqaluit.nu.ca

CONSULTANT

AECOM
101 18817 Stony Plain Rd NW
Edmonton, AB T5S 0C2, Canada
780.486.7000 tel
www.aecom.com

NOTICE:
THE EXISTENCE, LOCATION AND ELEVATION OF UTILITIES AND/OR CONCEALED STRUCTURES AT THE PROJECT SITE ARE NOT GUARANTEED BY AECOM CANADA LTD.

THE CONTRACTOR IS RESPONSIBLE FOR DETERMINING THE EXISTENCE, LOCATION AND ELEVATION OF ALL SUCH UTILITIES AND/OR STRUCTURES AND IS RESPONSIBLE FOR NOTIFYING THE APPROPRIATE COMPANY, DEPARTMENT OR PERSON(S) OF ITS INTENTION TO CARRY OUT ITS OPERATIONS.

REGISTRATION**ISSUE/REVISION**

U/R	DATE	DESCRIPTION
B	2021/09/09	ISSUED FOR 99% REVIEW
A	07/30/2021	ISSUED FOR 99% REVIEW
U/R	DATE	DESCRIPTION

KEY PLAN**PROJECT NUMBER**

60642509

SHEET TITLE

ELECTRICAL - SPECIFICATIONS

SHEET NUMBER

01-E-1004